

HR5 Northern Hardwoods®

Handrail

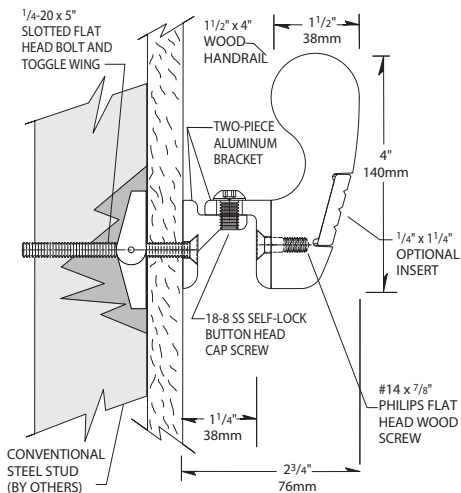

- 4" (102mm) height x 1-1/2" (38mm) gripping diameter, extends 3" (76mm) from the wall
- Enhance interiors with IPC rigid sheet, BioPrism™ Solid Surface or Wood insert options
- Combine with other wood Sign Frames, Handrails and Chair Rails for a classic combination
- Suited for elegant applications in low abuse areas
- Easy installation, clean-up and maintenance
- Available as pre-assembled units complete per your specifications or as stock lengths that require field cut corners
- All mounting fasteners are included with each order

IPC.1193/REV.6

HR5 Northern Hardwoods® Handrail

Suggested Specifications

PART 1 GENERAL

1.01 SUMMARY

A. Handrail systems for pedestrian safety and wall protection

1.02 SECTIONS INCLUDES

A. Northern Hardwoods® HR5 Handrail. Solid wood handrail in red oak, maple, FSC® Certified Ash or Bamboo. Available with optional decorative inserts.

1.03 REFERENCES

A. American National Standards Institute (ANSI)
B. American with Disabilities Act (ADA)
C. Environmental Protection Agency (EPA)
D. Kitchen Cabinets Manufacturers Association (KCMA)
E. National Emission Standards for Hazardous Air Pollutants (NESHAP)
F. National Fire Protection Association (NFPA)

1.04 SYSTEM DESCRIPTION

A. Performance Requirements: Provide wood handrail systems that conform to the following requirements of regulatory agencies and the quality control of IPC Door and Wall Protection Systems, Inpro Corporation.

1. Fire Performance Characteristics: Provide wood handrails that conform to NFPA Class A fire rating. Surface burning characteristics, as determined by ASTM E-84, shall be flame spread of 20 and smoke development of 30 for Oak, flame spread of 20 and smoke development of 50 for Bamboo.

2. Cold, heat and chemical resistance: Provide wood handrail with a finish that complies with the applicable provisions of ANSI/KCMA A161.1-1990 for cold check, heat and chemical resistance.

3. Environmental compliance: Provide wood handrail and with a finish that does not off gas or emit any VOC, after a full cure, as tested in accordance to the EPA, NESHAP, Method 24, 40CFR, Volume 60, Appendix A.

4. Code Compliance: Provide handrails that comply with all current ANSI and ADA requirements.

1.05 SUBMITTALS

A. Product Data: Manufacturer's printed product data for each product indicated in this section.
B. Detail Drawings: Mounting details with appropriate fasteners for specific project substrates.
C. Samples: Verification samples of handrail, 8" (203mm) long, in full size profiles of each type and color indicated.
D. Manufacturer's Installation Instructions: Printed installation instructions for each handrail.

1.06 DELIVERY, STORAGE AND HANDLING

A. Deliver materials in unopened factory packaging to the jobsite.
B. Inspect materials at delivery to assure that specified products have been received.
C. Store in original packaging in a climate controlled environment away from direct sunlight.

1.07 WARRANTY

A. Standard IPC Limited Lifetime Warranty against material and manufacturing defects.

PART 2 PRODUCTS

2.01 MANUFACTURERS

A. Acceptable Manufacturer: IPC Door and Wall Protection Systems, Inpro Corporation, PO Box 406, Muskego, WI 53150 USA; Telephone 800.222.5556, Fax: 888.715.8407, www.inprocorp.com
B. Substitutions: Not permitted
C. Provide all handrails and wall protection from a single manufacturer.

2.02 MANUFACTURED UNITS

A. Wood Handrail

1. HR4 Handrail, 5-1/2" (140mm) height x 1-1/2" (38mm) gripping diameter, extends 3" (76mm) from the wall.
a. Optional Decorative Inserts
1. Solid Wood Insert: Insert shall be .25" thick x 1.25" high, oak, maple, FSC® Certified Ash or bamboo. Solid wood insert shall have one smooth side and one side with three decorative v-grooves.
2. BioPrism™ Solid Surface Insert: Insert shall be .25" thick x 1.25" high BioPrism™ Solid Surface material.
3. IPC Rigid Sheet Insert: Insert shall be .040" thick x 1.25" high IPC Rigid Sheet. Material shall be IPC Rigid Vinyl Sheet or G2 Series Sheet.

2.03 MATERIALS

A. Wood: Shall be FAS grade, kiln dried, solid maple or red oak with moisture content of 5-9%.
B. Forest Stewardship Council® Certified Wood: Shall be kiln dried solid FSC® Certified Ash.
C. Bamboo: Shall be 100% bamboo, kiln dried, with a moisture content of 7-10%.
D. BioPrism™ Solid Surface: A bio polyester and acrylic hybrid resin with natural filler material.
1. The composition of BioPrism™ Solid Surface produces slight color variation between production cycles due to the innate and complex blending of natural minerals and man-made resin. *Inpro does not guarantee color match.*
E. Vinyl: IPC rigid vinyl sheet of .040" thickness shall be manufactured from chemical and stain resistant polyvinyl chloride with the addition of impact modifiers. No plasticizers shall be added (plasticizers may aid in bacterial growth).
F. G2, BioBlend: G2 Series Sheet of .040" thickness shall be manufactured from chemical and stain resistant, reformulated PETG with Biopolymer Blend.
G. Aluminum: Aluminum brackets shall be cast. Visible surfaces shall be polished.

2.04 COMPONENTS

A. Returns, outside corners and inside corners shall be solid wood or bamboo and a finish to match handrails.
B. Brackets
1. One Piece wood bracket matching the handrail, 1-1/2" deep x 1-1/2" high x 4" long.
2. Two piece cast aluminum bracket, 1-1/2" deep x 1-1/2" high x 3" long.
C. Fasteners: All mounting systems accessories appropriate for substrates indicated on the drawings shall be provided.

2.05 FINISHES

A. Wood/Bamboo Stain: Color of the handrail to be selected, by the architect, from the IPC stain selection. Bamboo color shall be neutral or carbonized.
B. Wood/Bamboo Finish: Handrail shall be finished with a water-based clear coat finish. Finish shall be a low luster satin finish.

PART 3 EXECUTION

3.01 INSTALLERS

A. Installer should be familiar with the installation of fine finished wood products.

3.02 EXAMINATION

A. Examine areas and conditions in which handrail will be installed.
1. Complete all finishing operations, including painting, before beginning installation of handrail system materials.

2. Wall surface shall be dry and free from dirt, grease and loose paint.

3.03 PREPARATION

A. General: Prior to installation, clean substrate to remove dust, debris and loose particles.

3.04 INSTALLATION

A. General: Locate the handrail as indicated on the approved detail drawing for the appropriate substrate and in compliance with the IPC installation instructions.

Install handrail level and plumb at the height indicated on the drawings.

B. Installation of the pre-assembled HR4 Handrail.

1. Pre-assembled handrails ship in pre-cut lengths with returns attached inside and outside corners are miter cut on the jobsite.
2. Layout and identify the components needed for each section to be installed. Determine bracket locations on the wall and drill appropriate size holes for the fasteners. Brackets should be 4" (102mm) from the returns and corners and spaced a maximum of 32" (813mm).
3. Bracket installation:
a. Attach the wall brackets to the wall with the correct fastener for the substrate.
b. Drill two 1/8" holes through the front of the handrail and into the mounting brackets. Attach handrail to the wall with two trim head screws per bracket.
4. Glue and pin nail inside and outside corner conditions. Fill the nail holes with wood putty from the touch up kit.
5. Cut and adhere optional decorative insert.
6. Alternate Two piece aluminum bracket installation:
a. Attach aluminum wall bracket to wall.
b. Attach Aluminum handrail bracket to back of handrail.
c. Attach handrail assemble to aluminum wall bracket.
C. Installation of stock length HR4 Handrails
1. Handrails ship in 8' - 16' (2.44m - 4.88m) lengths. Returns and corners must be field cut.
2. Cut the handrail to the required length allowing for returns and corners.
3. Field cut, glue and attach returns and corners.
4. Bracket installation:
a. Attach the wall brackets to the wall with the correct fastener for the substrate.
b. Drill two 1/8" holes through the front of the handrail and into the mounting brackets. Attach handrail to the wall with two trim head screws per bracket.
5. Glue and pin nail inside and outside corner conditions. Fill the nail holes with wood putty from the touch up kit.
6. Cut and adhere optional decorative insert.
7. Alternate Two piece aluminum bracket installation:
a. Attach aluminum wall bracket to wall.
b. Attach Aluminum handrail bracket to back of handrail.
c. Attach handrail assemble to aluminum wall bracket.

3.05 CLEANING

A. At completion of the installation, clean surfaces in accordance with the IPC clean-up and maintenance instructions.

Inprocorp.com • 800.222.5556 • 262.679.9010

World Headquarters S80 W18766 Apollo Drive, Muskego, WI 53150 USA

IPC®
DOOR + WALL PROTECTION SYSTEMS
A DIVISION OF INPRO®